SEALED UV DETECTORS

MODEL DI211-Cos USER HANDBOOK



DI211A-Cos
DI211B2-Cos
DI211AB-Cos

Handbook Ref No. IH002/Issue A
File Ref: DI211-v2b.doc

 **IRRADIAN**
Light Measurement Systems & Calibration

SEALED UV DETECTORS

MODEL DI211-Cos

USER HANDBOOK

CONTENTS:

1. Introduction
2. Specification
3. Circuit Connections
4. Cosine Angular Response
5. Irradiance Measurements
6. Sunlight Spectrum
7. Calibration Description
8. Care and Maintenance
9. Environmental Care, Recycling and Disposal

Handbook Update Log

<u>Issue</u>	<u>Date</u>	<u>Pages changed</u>
A	23/07/12	New Issue



1. INTRODUCTION

SEALED ULTRAVIOLET DETECTORS

The Irradian DI211-Cos sealed ultraviolet series detectors are designed for use with data loggers and weather stations, where the combinations of continuous monitoring, reliability and precision are required.

They are provided with a calibrated current sensitivity and comprise of a silicon or GaAsP photodiode and filter glass package with diffuser.

Key design features include:

- Self-cleaning input diffusers
- Stay dry diffuser with wide drainage slots
- Excellent cosine response
- Infinity error correction ring
- Aluminium body with resistant anodising
- Fully sealed, waterproof design
- High stability photodiodes

Three models are available covering the UVA, UVB and UVAB regions:

UVA: Model DI211A-Cos

UVB: Model DI211B2-Cos

UVAB: Model DI211AB-Cos

2. SPECIFICATION

DETECTOR

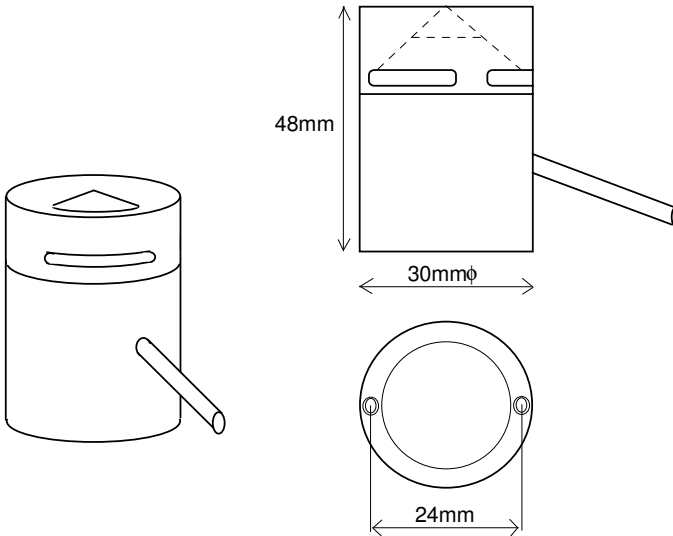

Diffuser Size:	15 mm ϕ , 177 mm ²
Detector Type(s):	Si Photodiode 33 mm ² area (UVA, UVB). GaAsP Photodiode 21 mm ² area (UVAB).
Dark Current(s):	50 pAmps at 25 °C (Si) 10 pAmps at 25 °C (GaAsP)
Temperature Coefficient(s):	0.05 % / °C (Si) -0.15 % / °C (GaAsP)
Temperature Range:	-10 to + 40 °C
Cable:	5 meter screened 50 ohm co-axial.
Connector:	Standard BNC plug.
Mounting:	Two M4 tapped holes on a 24 PCD.
Housing:	Hard black anodised aluminium.
Weight:	70g (excluding cable).

2. SPECIFICATION (continued):

CALIBRATION

The UVA, UVB and UVAB detector models are supplied with sensitivity calibrations as defined below:

Standard Calibration: The detector is calibrated at the peak wavelength response of each filter combination using a monochromatic source. The calibration plane is set at the front of the diffuser.

Mercury Calibration: The detector is calibrated at a wavelength corresponding to a mercury emission line. The calibration plane is set at the front of the diffuser.

Spectroradiometric Cal. The detector is calibrated to match the measurement over a given wavelength range with a spectroradiometer, of a particular source. The calibration plane is set at the front of the diffuser.

Accuracy: Absolute calibration accuracy $\pm 7.5\%$ traceable to NPL standards.

2. SPECIFICATION (continued):

MODEL DI211A-Cos

Peak Wavelength (λ_{pk}): 369 ± 2 nm

Bandwidth (FWHM): 30 ± 2 nm

Spectral Response: Refer to Figure 1.

Calibration Method: Mercury (@ 365 ± 1 nm)

Sensitivity (Typical): $2.0 \times 10^{-3} \mu\text{A/W/m}^2$ @ 365 nm

Cosine Corrected: Within $\pm 5\%$ up to 70°
Refer to Figure 5.

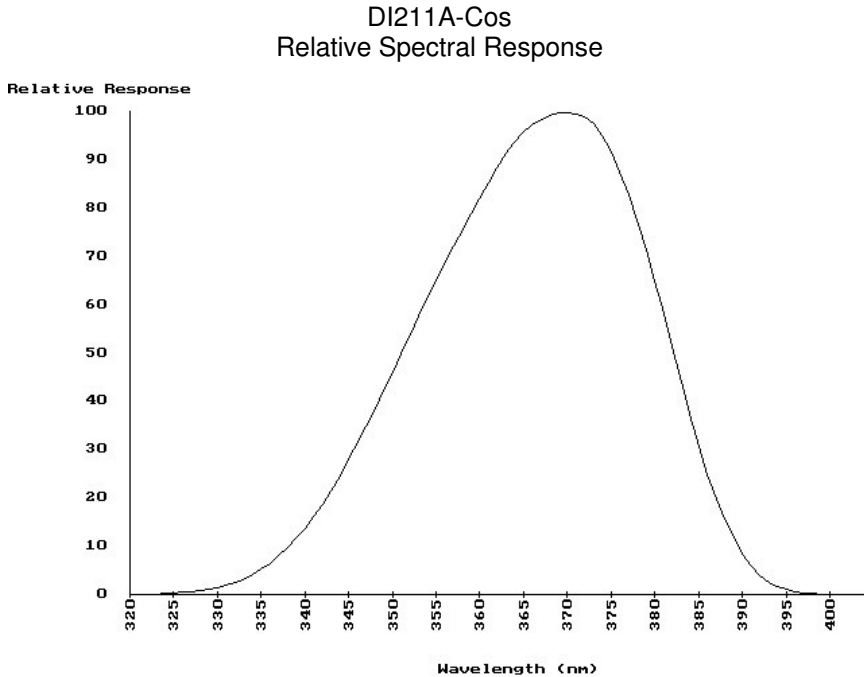

Figure 1

2. SPECIFICATION (continued):

MODEL DI211B2-Cos

Peak Wavelength (λ_{pk}):	311 \pm 2 nm
Bandwidth (FWHM):	19 \pm 2 nm
Spectral Response:	Refer to Figure 2.
Calibration Method:	Standard
Sensitivity (Typical):	1.0 $\times 10^{-3}$ μ A/W/m ² @ 311 nm
Cosine Corrected:	Within \pm 5 % up to 70° Refer to Figure 5.

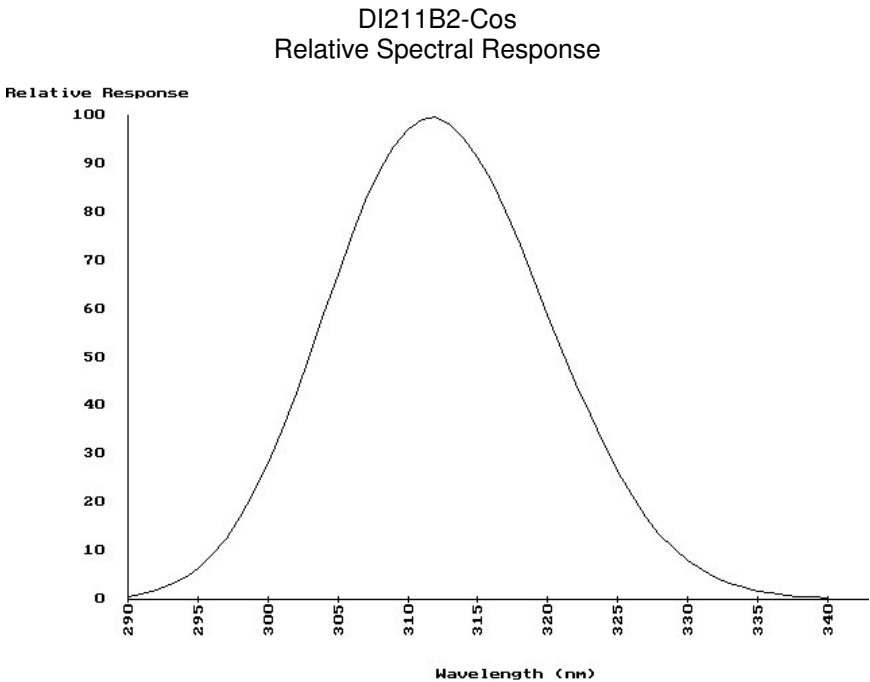

Figure 2

2. SPECIFICATION (continued):

MODEL DI211AB-Cos

Peak Wavelength (λ_{pk}): 352 ± 5 nm

Bandwidth (FWHM): 79 ± 4 nm

Spectral Response: Refer to Figure 3.

Calibration Method: Standard

Sensitivity (Typical): 4.0×10^{-3} $\mu\text{A/W/m}^2$ @ 350 nm

Cosine Corrected: Within $\pm 5\%$ up to 70°
Refer to Figure 5.

DI211AB-Cos
Relative Spectral Response

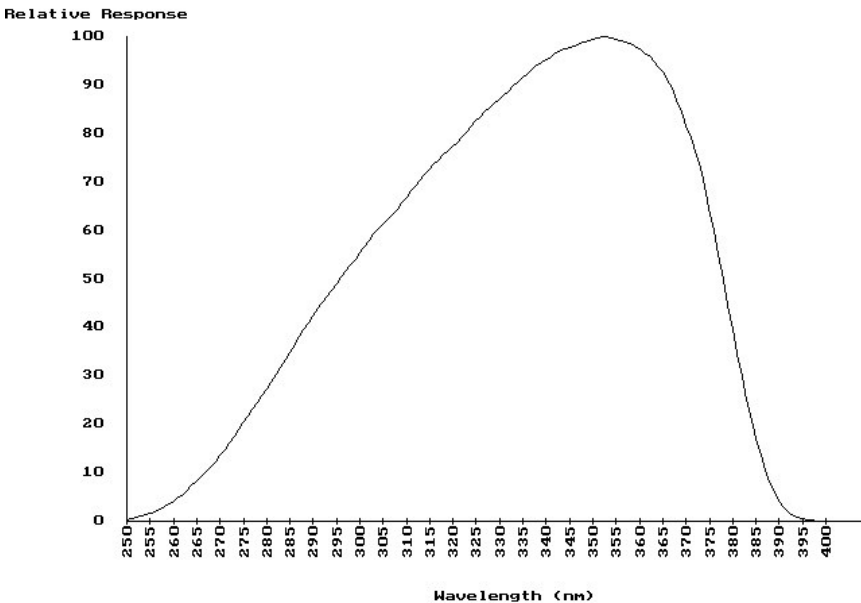

Figure 3

3. CIRCUIT CONNECTIONS

CURRENT TO VOLTAGE CONVERSION

A simple conversion of the detector current output to a voltage (V_{out}) is possible with the addition of an operational amplifier (A) and a feedback resistor (R_f). Refer to Figure 4.

Example Conversion Circuits

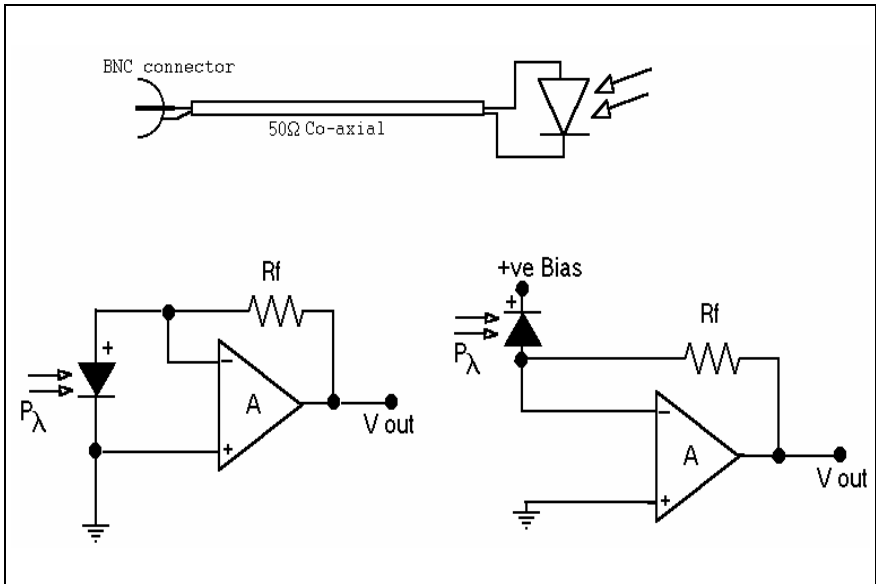

Figure 4

4. COSINE ANGULAR RESPONSE

COSINE CORRECTED INPUT

Angular Response: Accurately cosine corrected to Lambert's Cosine Law.

Maximum error is less than $\pm 5\%$ from true response to 70° from normal incidence.
Refer to Figure 5.

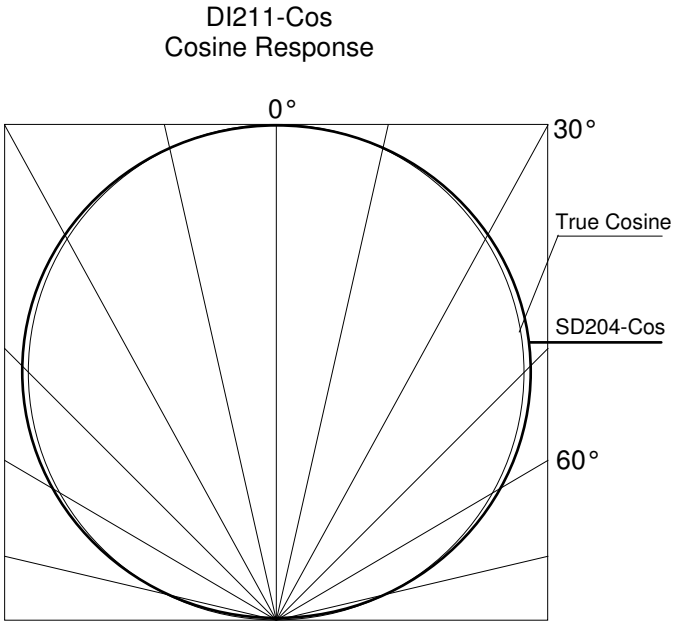

Figure 5

5. IRRADIANCE MEASUREMENTS

MEASUREMENT TECHNIQUE

Caution: Ultra-violet radiation is hazardous to both eyes and skin. Take great care to avoid unnecessary personal exposure during measurements.

Irradiance is the measurement of radiometric light per unit area, watts per metre, (W/m^2). The part of the spectrum to be measured is defined by the filter fitted with the detector. Ideally this should be a filter with a square spectral response. In practice it rarely is and the filter is defined with a peak response wavelength (λ_{pk}) and a full width half maximum, (FWHM) bandwidth. In all applications it is vital to know the part of the spectrum being measured by the detector and filter, and if possible to know the spectrum of the light source. In addition the detector should be calibrated to best suit the measurement conditions. It may even be necessary to have more than one calibration factor for the same detector and filter combination.

For most applications the measurement plane is horizontal and a cosine corrected diffuser is fitted to the front of the detector assembly. If the working surface is not horizontal then placing the detector on or parallel to the worktop is a more representative measurement of irradiance.

Note that all the light sources in the hemisphere above the detector will contribute to the measurement. The sources may be obvious, lamps or windows or even walls or other reflecting surfaces. Take care not to shadow the detector during all measurements.

A useful technique for measuring the sensitivity of the detector filter to non ultra violet light is to place a *high pass* filter glass over the front of the detector and record the reading. If the *high pass* filter blocks all the light across the spectral response region of the UV filter then a zero reading would imply the detector/filter is only sensitive to the UV light. Readings other than zero would imply there is some sensitivity to visible or near infra-red light.

6. SUNLIGHT SPECTRUM

ULTRAVIOLET MEASUREMENTS

Spectral irradiance scan taken on 1st July 1990 at approximately midday in bright sunshine. Latitude 54° North Longitude 2° West using an Irradian SR9910-PC double grating spectroradiometer. Refer to Figure 6.

Typical Sunlight Spectrum

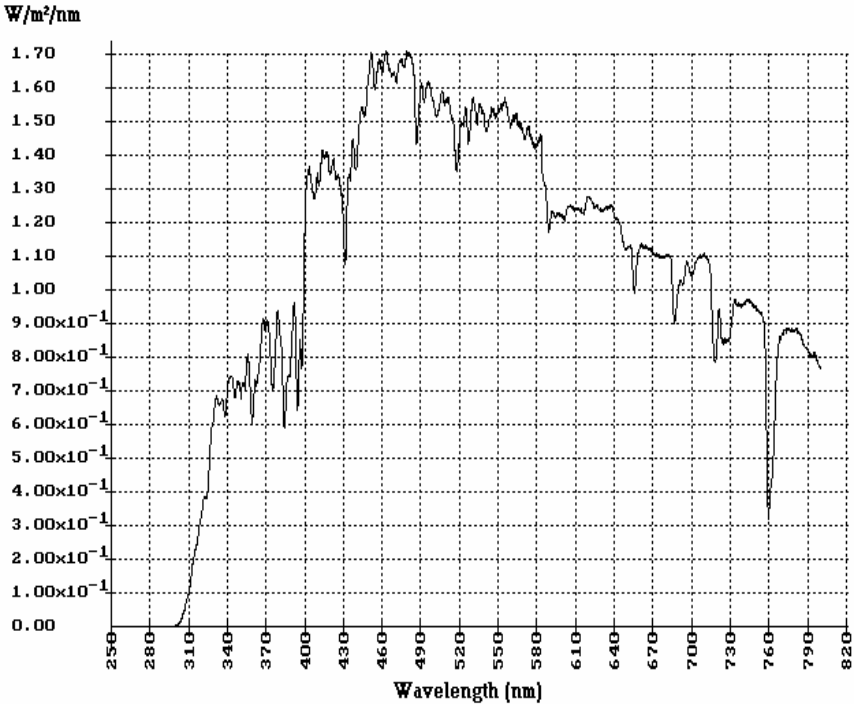

Figure 6

7. CALIBRATION DESCRIPTION

TRACEABILITY AND ACCURACY

Irradian holds a number of tungsten halogen lamps, photometers and silicon photodiodes which are routinely calibrated by the National Physics Laboratory in the UK.

During manufacture each filter/diffuser combination for every detector has its spectral response measured. Changes are made to the filter glasses if the peak wavelength or filter bandwidth exceed the specification limits. A graph of the final filter/detector response is provided. The data on a disk is also available on request for importing to a spreadsheet.

The detector and filter/diffuser combination is calibrated using monochromatic light at the peak wavelength of each filter or at a specified wavelength (refer to the individual calibration certificate). Other calibration techniques can be applied to suit the users application. For example matching the detector output to the output from a high accuracy spectroradiometer (SR9910-v7) for a particular light source.

As with all measuring equipment a routine calibration is recommended, typically annually, but with frequent use by a number of different users a shorter recalibration period may be necessary.

Contact Irradian for any calibration requirements for this product and for further information.

8. CARE AND MAINTENANCE

LOOKING AFTER THE DETECTOR

1. The DI211-Cos detector should be cleaned using a moist cloth with detergent, solvent or alcohol.
2. The diffuser on the detector should be kept clean at all times.
3. The detector is a precision instrument, protect it from shocks.
4. Avoid supporting the detector by the cable.

9. ENVIRONMENTAL CARE, RECYCLING AND DISPOSAL

WASTE ELECTRICAL AND ELECTRONIC EQUIPMENT

The purpose of the European Commission WEEE directive (Waste Electrical and Electronic Equipment; 2002/96/EC) is to ensure that electrical and electronic products are recycled using the best treatments, recovery and recycling techniques that are currently available. This is so that high health standards and a lasting environmental protection can be achieved and maintained.

This product has been designed and manufactured using high quality materials and components, many of which can be recycled and reused.

Please remember to observe the local regulations that govern both the disposal of the packaging materials accompanying this product and any used batteries.



DO NOT DISPOSE OF THIS PRODUCT IN YOUR GENERAL WASTE BIN.

Please inform yourself about your local WEEE collection system which is available for electrical and electronic products that are marked with the symbol shown here.

When disposing of this meter, please use one of the following options:

1. Use your local designated WEEE collection facilities to dispose of the complete product (including cables, detectors, filters & accessories).
2. Return the complete product back to Irradian, marking it clearly as intended for WEEE disposal.

This page left blank.

This page left blank.

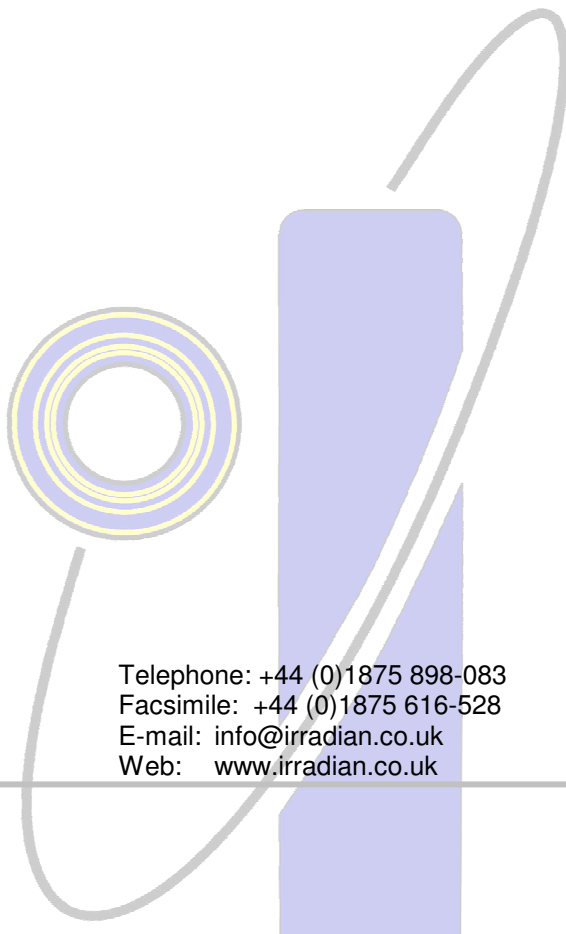

IRRADIAN Ltd.

9 Elphinstone Road
Tranent
East Lothian
Scotland EH33 2LG

Telephone: +44 (0)1875 898-083
Facsimile: +44 (0)1875 616-528
E-mail: info@irradian.co.uk
Web: www.irradian.co.uk
